

Contour™ Fascia

 STRATCO





A unique fascia that blends smooth modern curves with strength and practical design.

CRAFTED WITH STYLE

The trend setting contemporary style of Contour™ Fascia will set your home apart from the rest. Its smooth flowing lines and modern curves will accentuate the architecture of your home, giving it visual appeal and a fresh, uncluttered finish that only Contour Fascia can provide. The rounded base on Contour Fascia provides a smooth finish that is complimented by bold crafted stiffening ribs.

Contour Fascia is available in a full spectrum of colours to compliment your home and environment. Its clean, attractive curves will blend with both modern and heritage styled buildings. Installing Contour Fascia on a new or existing home is easy because the Contour Fascia System is compatible with normal building construction.

LASTING QUALITY

Unlike timber, the Stratco Contour Fascia System will provide a consistent, quality product that does not warp, knot or crack and will keep looking good for many years to come. Stratco Contour Fascia is manufactured from hi-tensile steel. It is engineered with stronger and deeper stiffening ribs to reduce rippling in the face of the fascia. Larger bend radii minimise the risk of micro paint cracking providing longer life. The extra width at the top of the Contour Fascia provides added stiffness, which assists in maintaining straightness and minimises bowing along the length of the fascia. This extra width provides better support for the back of the gutter and also makes the installation process easier. Contour Fascia has been designed to comply with the relevant Australian Standards.

ACCESSORIES

Contour Fascia is finished with die-cast internal and external corner mitres. They are designed to continue the smooth form of the fascia around the corners of the house and provide accurate angles that are easy to install.

A rollformed 100mm x 50mm downpipe with flutes that suit the fascia profile and provide additional stiffness is also available. Cast elbows make the installation quick and easy. In addition, a wide range of round, square and rectangular downpipes complete the package.

Stratco manufactures a wide range of gutters that are compatible with the Contour Fascia System. These include the OG, Quad, Smoothline® and Square gutters.



DESIGN CONSIDERATIONS

Contour™ Fascia and gutter system is compatible with normal building construction, and is suitable for use up to wind classification N3 (W41). Fascia brackets should be secured to rafters with at least three fasteners (only one fastener in a slotted hole). It is important that the building structure is sound, and that the installer takes adequate measures to ensure their safety when installing the product, particularly when two story construction is involved. Note that for a jack rafter to be considered as a support, it must be adequately connected to the hip rafter. Stratco recommends that eaves gutters receive a minimum 1 in 500 fall.

Fascia Support Spacing

Sheet roofing will require a purlin or batten immediately behind the fascia to support the sheet end span. Rafter brackets are required at maximum 1200mm centres for sheet roofing. The maximum support spacing for tile roofing is 600mm if the fascia is used to support tiles. If a tilt batten is used adjacent to the fascia to support the end tiles, rafter brackets are allowed at maximum 1200mm centres.

Material Compatibility





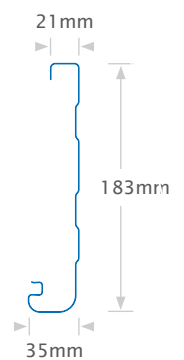





Drainage from copper or lead products (including roof flashings) should not be allowed to discharge on to zinc/alum or pre-painted steel components. Similarly, lead or copper components should not be installed in contact with zinc/alum steel. Each of these combinations will lead to premature corrosion.

Drainage from copper, zinc/alum and pre-painted steel, translucent (or other inert material) should not be allowed to discharge onto galvanised products.

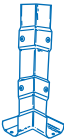

BMT (mm) 0.45
Tensile (MPa) G550

COMPONENTS

| | | | | |
|---|---|---|---|---|
|  |  |  |  |  |
| Contour Rafter Bracket | Barge Apex Cover | Barge Mould LH and RH | Stop End LH and RH | Joining Sleeve |
|  |  |  |  |  |
| 90° External Mitre | 90° Internal Mitre | 135° External Mitre | 135° Internal Mitre | Contour Suspension Clip |





EAVES CONSTRUCTION

Contour Fascia is able to be used on all homes, and is easily set out and installed. After checking that foot and plumb cuts are correct, determine the eaves height by reference to the plan and location of soffit supports. The soffit usually finishes at the top of the window reveal, unless otherwise specified. The distance from the inside of the soffit groove in the bracket to the wall line is the eaves width. Using these two dimensions and a spirit level, rafter brackets at either end of the house can be located, with the remainder fitted in place using a string line and bevel square. After all brackets have been installed the fascia is simply snapped into position.

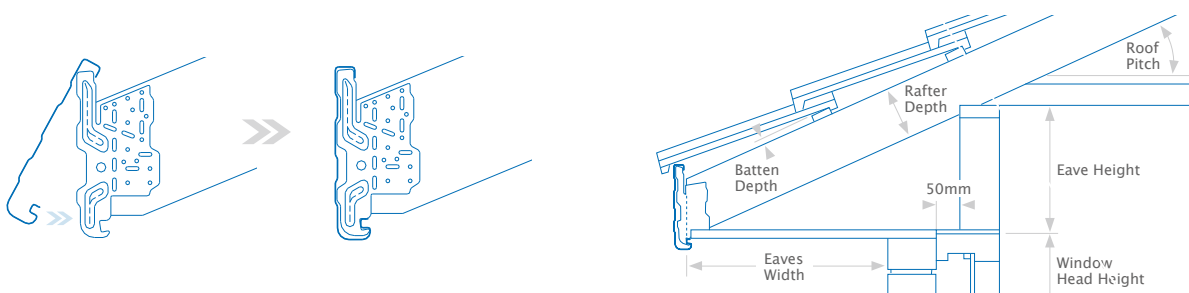

FINISHING OFF

Internal and external fascia mitres are available for ease of installation and a superior finish. Joining two lengths of fascia together is easily achieved by using a joining sleeve. Mitres and joining sleeves are simply riveted to the fascia through the pre-drilled holes.

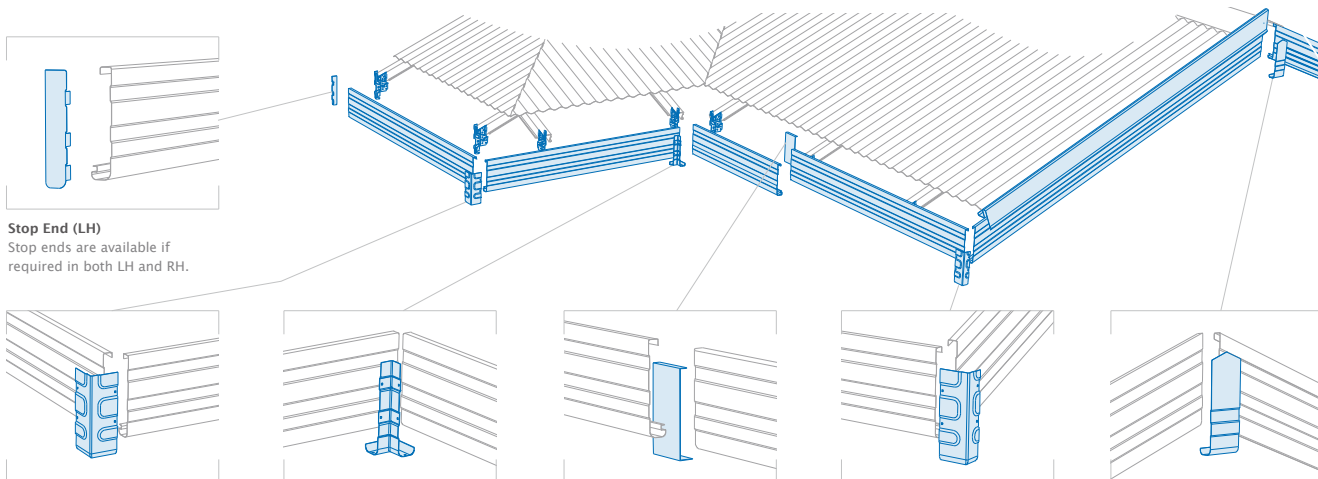

Stop End (LH)
Stop ends are available if required in both LH and RH.

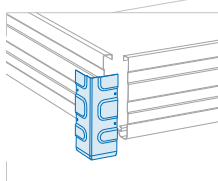

External Mitre
Trim fascia to required length. Slide external mitre over fascia and fix with 3.2mm blind rivets through locating holes.

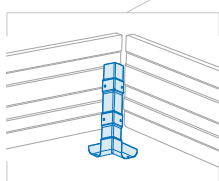

Internal Mitre
Trim fascia to required length. Slide internal mitre over fascia and fix with 3.2mm blind rivets through locating holes.

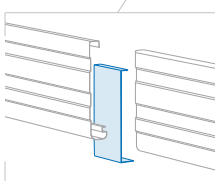

Joining Sleeve
Slide two fascia ends over joining sleeve until they meet in the middle. Fix with 3.2mm blind rivets.

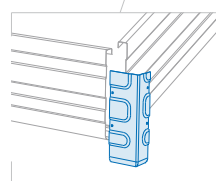

Barge Mould (RH)
Mitre ends of barge to suit roof pitch. Fix long leg of barge mould to fascia and short leg to barge with 3.2mm blind rivets.

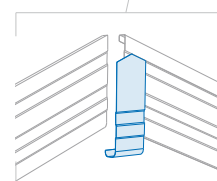

Barge Apex Cover
Fix barge apex cover to installed barge with 3.2mm blind rivets and trim excess material.





SIMPLE BARGES FOR STEEL AND TIMBER FRAMING

Now the simple elegant lines of your fascia can continue up the barges providing a consistent look all around the house. The junction between fascia and barge is easily completed using a barge mould.

Steel Frame

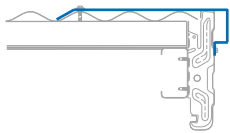
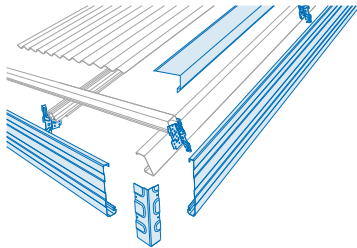

Barge Capping Detail

Timber Frame

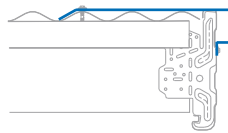
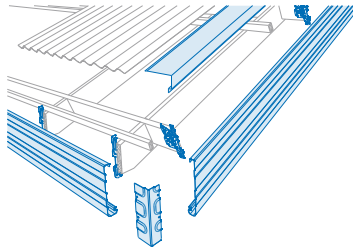

Barge Capping Detail

Barge Gutter for tile roofing

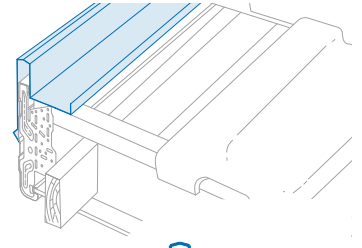

Barge Gutter Detail

GUTTER INSTALLATION

Roll In Clips

Push suspension clip up from rear and into the vertical position.

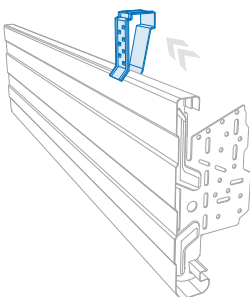

Clip Spacing

Knock suspension clip down with fist. Place at 1.2 metre intervals.

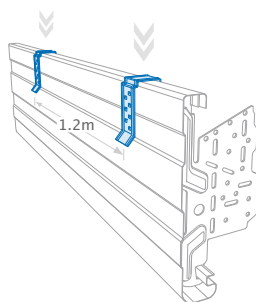

Install Gutter

Pull gutter upwards until suspension clip engages.

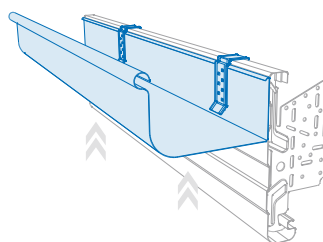

Fix Internal Straps

Roll gutter strap into bead and press over top of fascia.

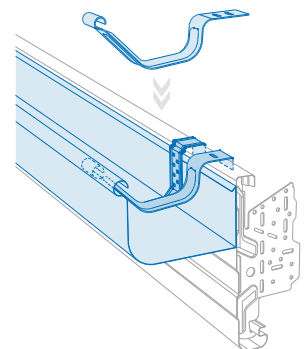

MEASURING YOUR PROJECT

If you have an accurate plan drawing of your building, the lengths of fascia required for your project can be determined by measuring off the plan. Alternatively you can physically measure your building to determine fascia lengths.

Measure each run of horizontal fascia and add an additional 200mm trimming allowance to each length measured to obtain your order length. For long fascia runs we suggest ordering multiple lengths and joining sleeves to reduce delivery costs and to increase ease of handling. Recommended max length = 9000mm.

If using fascia as barge we can again use an accurate plan drawing including a roof pitch and some simple trigonometry to determine the required length. Firstly you need to determine the distance from the building edge to ridge line + eave, this horizontal distance can be divided by the cosine of the roof pitch to give you the barge length. Add 300mm trimming allowance to the calculated barge length to obtain your order length. Or alternatively you can physically measure your building's barge length and add a 300mm trimming allowance.

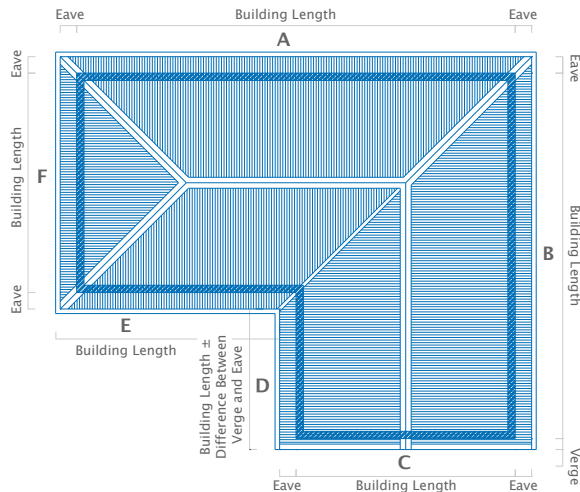

A – Fascia length = building length + eave + 200mm trimming allowance. (max recommended length = 9000mm)

B – Fascia length = building length + eave + verge + 200mm trimming allowance.

C – Fascia/Barge length = (1/2 building length + eave)/cosine of the roof pitch + 300mm trimming allowance.

D – Fascia length = building length ± verge and eave difference + 200mm trimming allowance.

E – Fascia length = building length + 200mm trimming allowance.

F – Fascia length = building length + eaves + 200mm trimming allowance.

ORDERING YOUR FASCIA

Stratco Contour fascia is custom rolled to your required length, allowing you to minimise waste and reduce the number of joins. Our minimum roll length is 1000mm. If you require a length less than the minimum, add it to another length and then trim on-site to minimise unusable off-cut.

- Include:
- Type and quantity of accessories required to complete your project.
 - Number of rafter brackets: total l/m of fascia (divide by 1200mm for steel roofs and tile roofs with tilt batten, or 600mm for tile roofs without tilt batten) + one per length of fascia + round up to nearest 10.
 - Mitres: total number fascia corners (define as external or internal).
 - Joining sleeves: where two lengths join together on a straight run.
 - Apex covers: at the apex of every gable.
 - Suspension clips: total l/m of horizontal fascia /1200mm + one per length of fascia + round up to nearest 10 (not used with fascia as barge).

MAINTENANCE REQUIREMENTS

The performance of Contour Fascia over time depends on its correct application and maintenance. Maintenance should be performed as often as is required to remove any dirt, salt and pollutants. Where Contour Fascia is used in severely corrosive environments, cleaning should be performed more often.

Refer to the Stratco "Selection, Use and Maintenance" brochure, for more detailed information about the correct use and maintenance of this product.

QUEENSLAND

- ORMEAU Ph: (07) 3451 4444** 1 Mavis Crt
 • **CRESTMEAD Ph: 3451 4411** 179 Magnesium Dve
 • **TOOWOOMBA Ph: 4638 9322** 167 Herries St
 • **VIRGINIA Ph: 3451 4411** 1/2034 Sandgate Rd
 • **CABOOLTURE Ph: 5431 4100** 17 Concorde Pl
 • **MAROOCHYDORE Ph: 5351 0100** 14 Pike St, Kunda Park
 • **BIGGERA WATERS Ph: 3086 4200** 12 Gateway Drive
 • **GOLD COAST Ph: 3451 4411** 108 Eastlake St, Carrara
 • **CAPALABA Ph: 3451 4411** Cnr. Smith St & Redland Bay Rd
 • **ARCHERFIELD Ph: 3451 4411** Cnr. Beaudesert & Granard Rd
 • **REDBANK PLAINS Ph: 3451 4411** 326 Kruger Pde

NEW SOUTH WALES

- HUNTINGWOOD Ph: (02) 8811 7200** 15 Liberty Rd
 • **CAMPBELLTOWN Ph: 8811 7211** 22 Blaxland Rd
 • **PENRITH Ph: 8811 7211** 125 Coreen Ave
 • **THORNTON Ph: 4922 2777** 2 Hartley Dve
 • **ORANGE Ph: 6362 2160** 5 Colliers Ave

AUSTRALIAN CAPITAL TERRITORY

- FYSHWICK Ph: (02) 6280 5905** 25 Tennant St

VICTORIA

- EPPING Ph: (03) 9409 9260** 17 Scanlon Dr
 • **DEER PARK Ph: 9409 9260** 1027 Western Hwy
 • **FERNTREE GULLY Ph: 9409 9260** 881 Burwood Hwy
 • **DANDENONG Ph: 9409 9260** 14 Princes Hwy, Doveton

SOUTH AUSTRALIA

- GEPPTS CROSS Ph: (08) 8349 5559** 125 Cavan Rd
 • **RICHMOND Ph: 8349 5559** 221 Marion Rd, Marleston
 • **ST MARYS Ph: 8349 5559** 1197 South Rd
 • **LONSDALE Ph: 8349 5559** Cnr. Dyson & O'Sullivan Beach Rd
 • **ST AGNES Ph: 8349 5559** 129 Tolley Rd
 • **GAWLER Ph: 8522 1132** 16 Main North Rd, Willaston
 • **GOOLWA Ph: 8555 2825** 29 Hutchinson St
 • **VICTOR HARBOR Ph: 8552 5164** 95 Victoria St
 • **MURRAY BRIDGE Ph: 8531 9191** 15 Hindmarsh Rd
 • **KADINA Ph: 8828 1555** 9 Kennett St
 • **RIVERLAND Ph: 8582 4666** 53 Zante Rd, Berri
 • **PORT AUGUSTA Ph: 8642 0300** 70 Victoria Pde
 • **WHYALLA Ph: 8645 7344** 50 Ian St, Whyalla Norrie

WESTERN AUSTRALIA

- CANNING VALE Ph: (08) 9455 5111** 183-189 Bannister Rd
 • **MALAGA Ph: 9455 5111** Cnr. Marshall Rd & Energy St
 • **BALCATT A Ph: 9455 5111** 140 Balcatta Rd
 • **MANDURAH Ph: 9455 5111** 11 Fitzgerald Rd
 • **BUNBURY Ph: 9791 4200** Cnr. Strickland St & Zaknic Pl
 • **BUSSELTON Ph: 9752 3122** 18 Wright St
 • **KALGOORLIE Ph: 9080 8080** 8 Federal Rd
 • **BROOME Ph: 9191 3800** 371 Tanami Dr

NORTHERN TERRITORY

- BERRIMAH Ph: (08) 8944 2300** 780 Stuart Hwy
 • **ALICE SPRINGS Ph: 8950 9898** 6 Ghan Rd
 • **KUNUNURRA Ph: 9169 1900** 2 Cocus Wy WA

NEW ZEALAND

- CHRISTCHURCH Ph: (03) 338 9063** 55 Hands Rd
 • **NAPIER Ph: (06) 843 6159** 65 Niven St, Onekawa